

## 2021 학년도 기계공학과 CADD (MEE1002)

CADD(Computer Aided Design and Drafting)

한양대학교  
터보기계연구실  
Prof. Keun Ryu

2021년 9월 27일



**HANYANG UNIVERSITY**



## CONTENTS

**I** 2D Sketch 실습(Trim, Corner, Transform)

**II** 예제 도면을 통한 실습

CADD (Computer Aided Design and Drafting)

# I 2D Sketch 실습

# 1 CADD(Computer Aided Design and Drafting)

## 2D Sketch 실습

### Corner

#### 1-1 Trim All Elements

- 선택한 두 개의 Elements를 모두 제거하며 라운드 생성

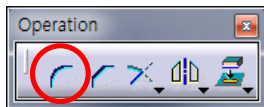
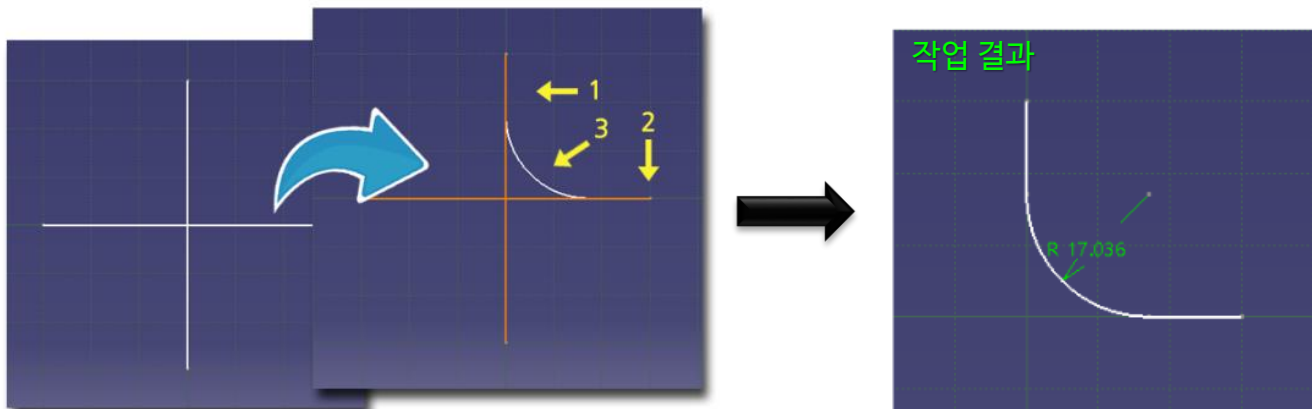

# 1 CADD (Computer Aided Design and Drafting)

## 2D Sketch 실습

### Corner

#### 1-2 Trim First Elements

- 두 개의 Elements 중 첫 번째 선택한 Element만 제거하며 라운드 생성

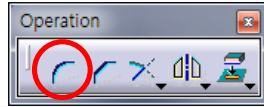
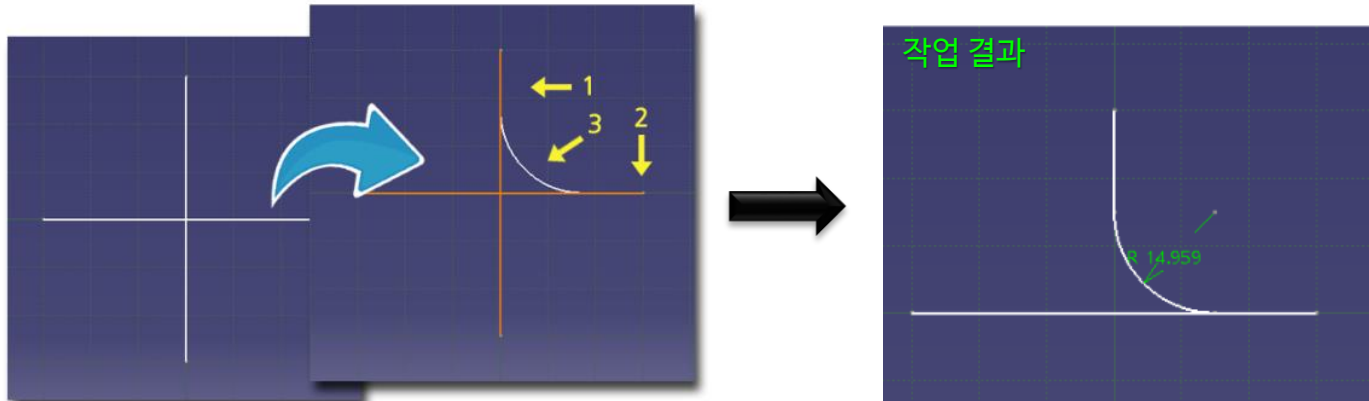

# 1 CADD (Computer Aided Design and Drafting)

## 2D Sketch 실습

### Corner

#### 1-3 No Trim

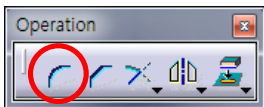

- 선택한 두 개의 Elements를 유지한 상태로 라운드 생성

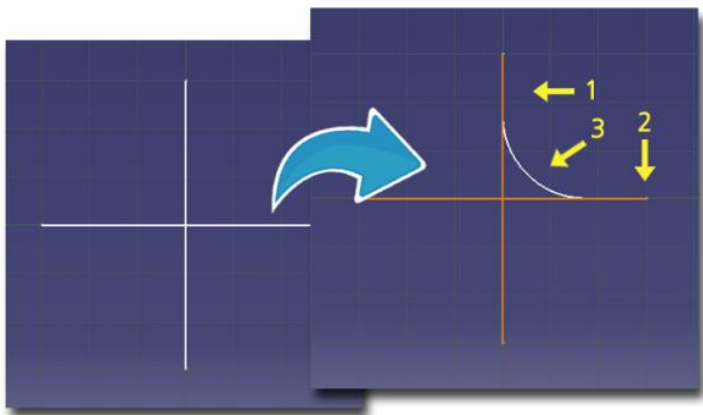

# 1 CADD(Computer Aided Design and Drafting)

## 2D Sketch 실습

### Corner

#### 1-4 Standard Lines Trim

- 선택한 두 개의 Elements를 실선 형태로 만들며 라운드 생성

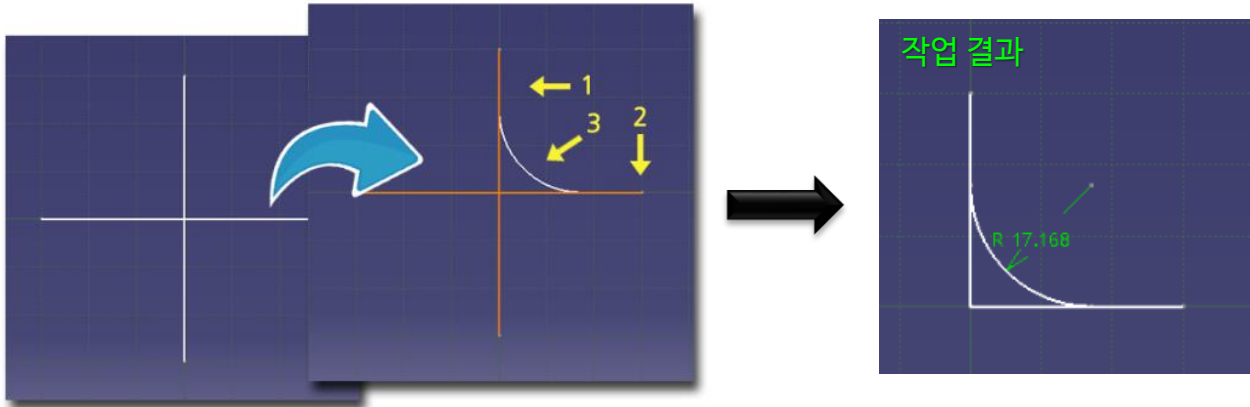

# 1 CADD(Computer Aided Design and Drafting)

## 2D Sketch 실습

### Corner

#### 1-5 Construction Lines Trim

- 선택한 두 개의 Elements를 보조라인으로 만들며 라운드 생성

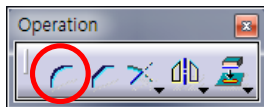
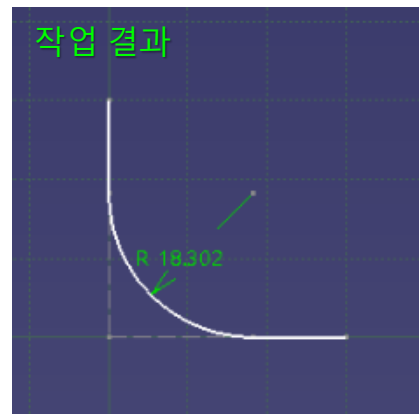
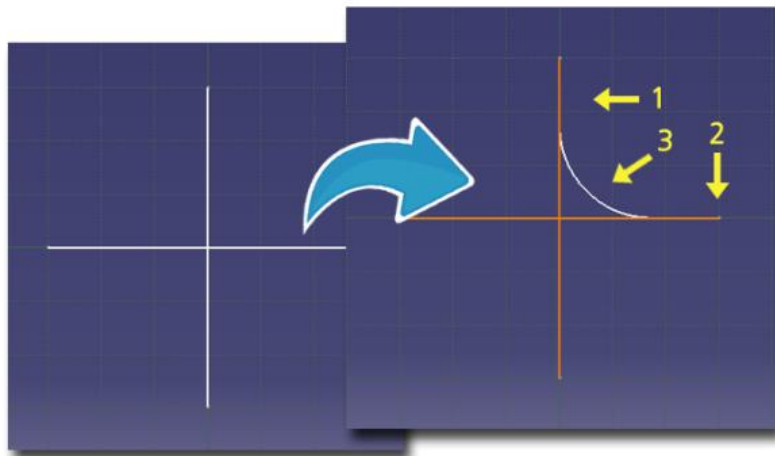



# 1 CADD(Computer Aided Design and Drafting)

## 2D Sketch 실습

### Corner

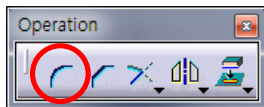

#### 1-6 Construction Lines No Trim

- 선택한 두 개의 Elements를 보조라인으로 만들며 상태 유지하며 라운드 생성

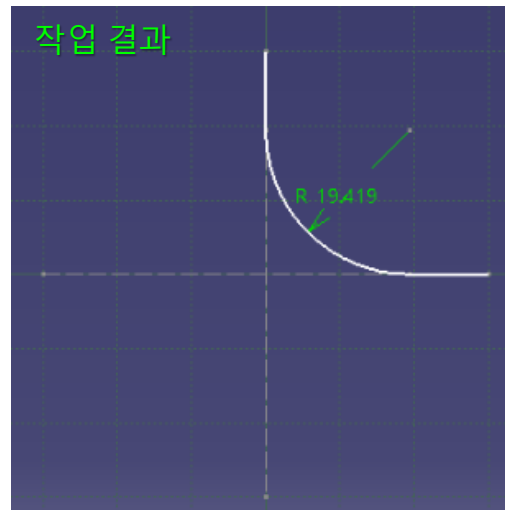
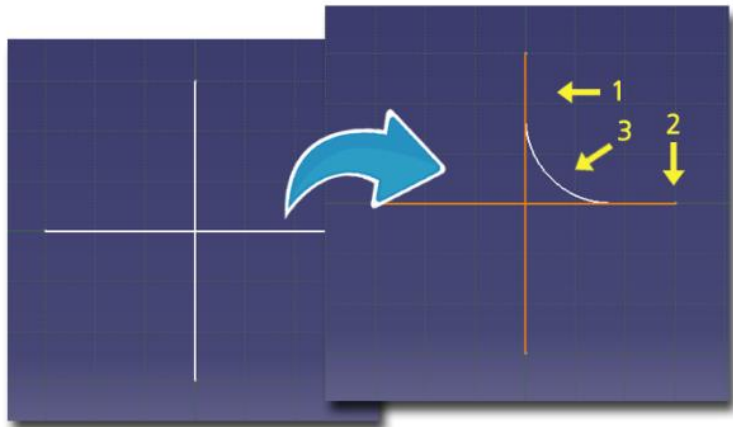

# 1 CADD(Computer Aided Design and Drafting)

## 2D Sketch 실습

### Chamfer

#### 2-2 Trim First Elements

- 두 개의 Elements 중 첫번째 선택한 Element만 제거하며 모따기

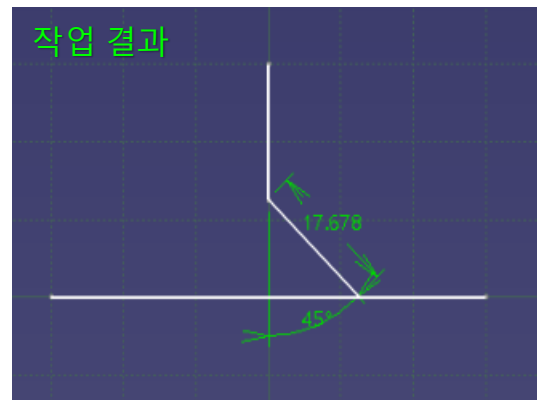
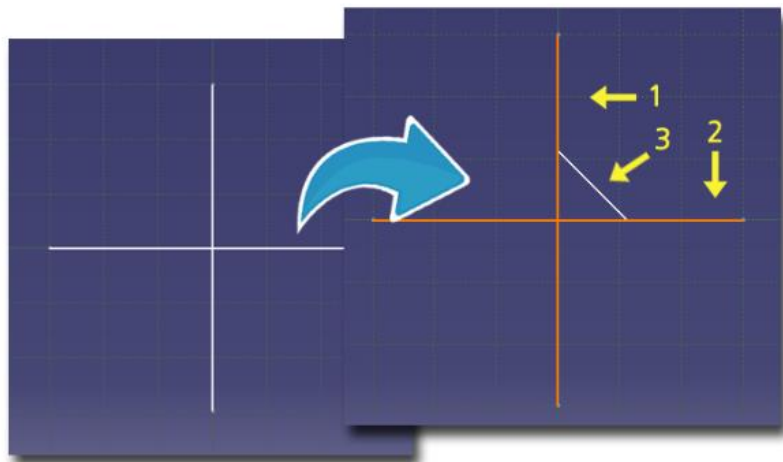
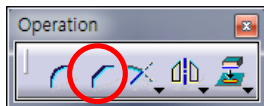

# 1 CADD (Computer Aided Design and Drafting)

## 2D Sketch 실습

### Chamfer

#### 2-3 No Trim

- 두 개의 Elements 를 남겨놓고 모따기

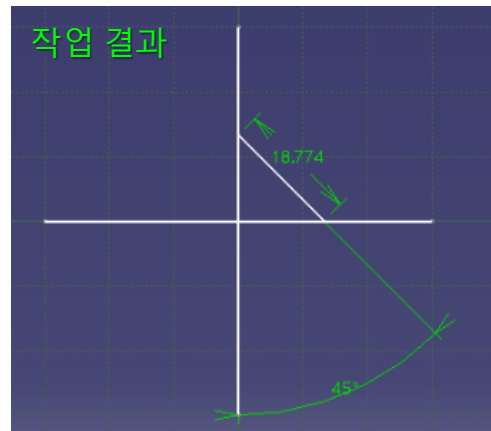
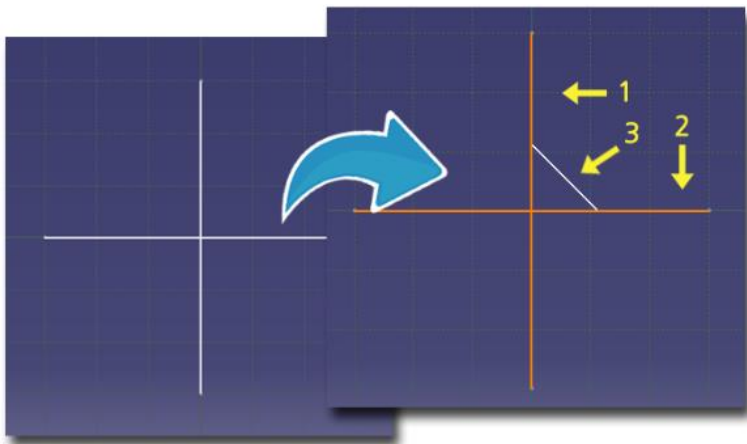
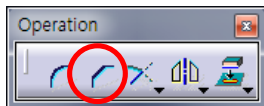

# 1 CADD(Computer Aided Design and Drafting)

## 2D Sketch 실습

### Chamfer

#### 2-4 Standard Lines Trim

- 선택한 두 개의 Elements를 실선 형태로 만들어 모따기

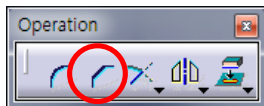
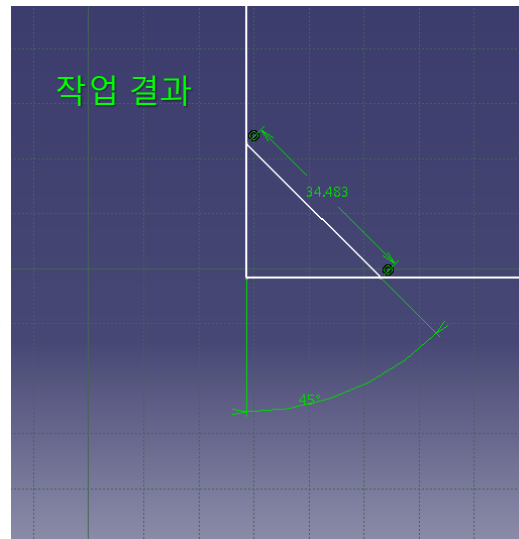
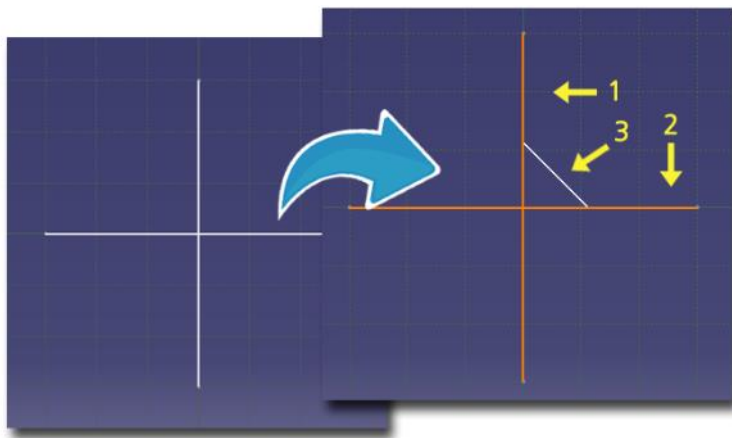

# 1 CADD(Computer Aided Design and Drafting)

## 2D Sketch 실습

### Chamfer

#### 2-5 Construction Lines Trim

- 선택한 두 개의 Elements를 보조 라인으로 만들며 모따기

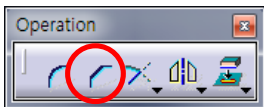
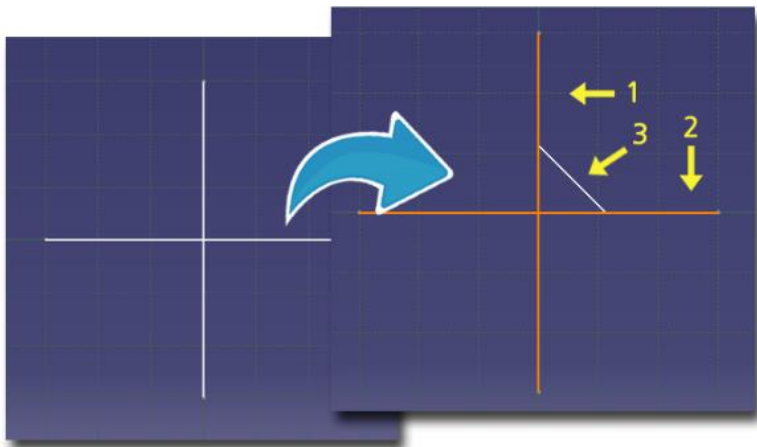

# 1 CADD(Computer Aided Design and Drafting)

## 2D Sketch 실습

### Chamfer

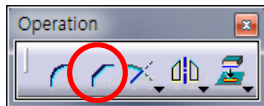

#### 2-6 Construction Lines No Trim

- 선택한 두 개의 Elements를 보조 라인으로 만들며 상태 유지하며 모따기

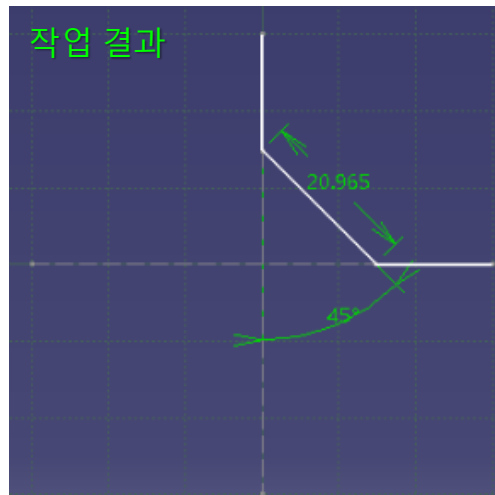
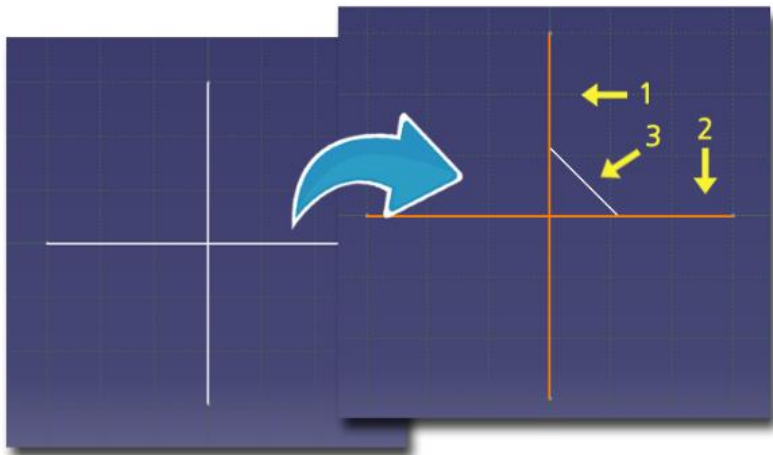

# 1 CADD (Computer Aided Design and Drafting)

## 2D Sketch 실습

### Chamfer

#### 2-7 치수 부여 방법

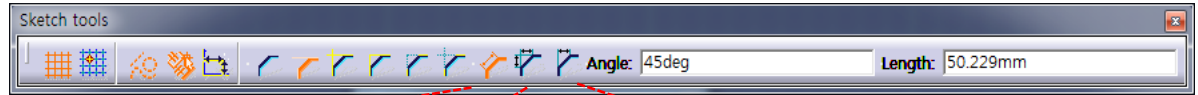
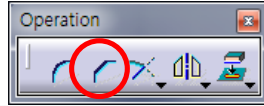

#### 1. Angle and Hypotenuse

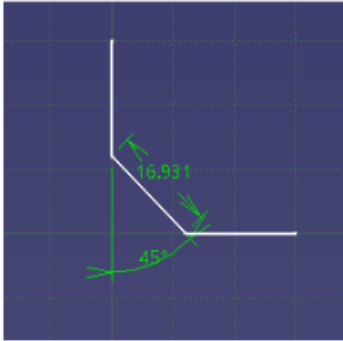

#### 2. First and Second Length

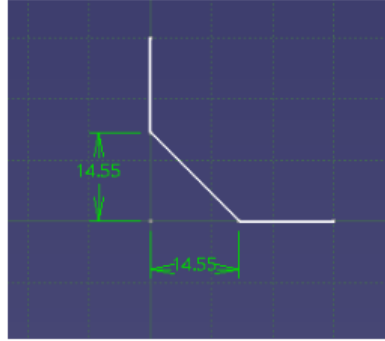

#### 3. Angle and First Length

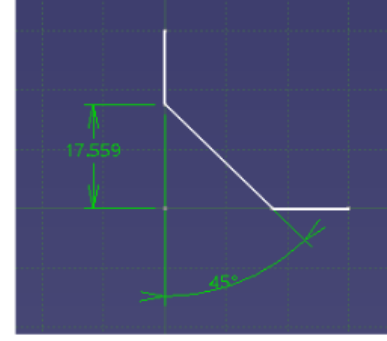

# 1 CADD (Computer Aided Design and Drafting)

## 2D Sketch 실습

### Trim

#### 3- 1Trim

- 두 개의 Element를 교차점 기준으로 제거 또는 연장하는 기능
- ✓ Element 선택 시 남겨질 부분을 선택한다.
- ✓ Sketch Tools에 2가지 기능이 있다.

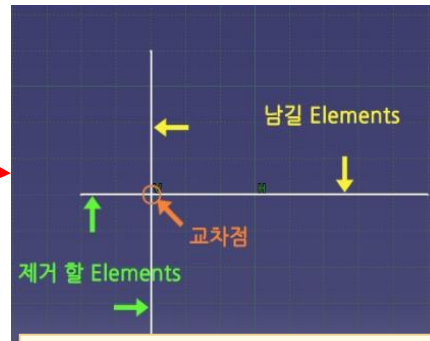
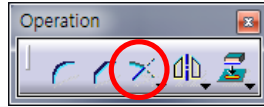

1. Trim All Elements





# 1 CADD (Computer Aided Design and Drafting)

## 2D Sketch 실습

### Trim

#### 3- 1Trim

- 두 개의 Element를 교차점 기준으로 제거 또는 연장하는 기능
- ✓ Element 선택 시 남겨질 부분을 선택한다.
- ✓ Sketch Tools에 2가지 기능이 있다.

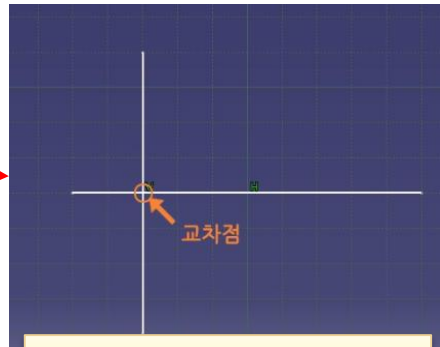
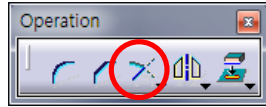

2. Trim First Elements

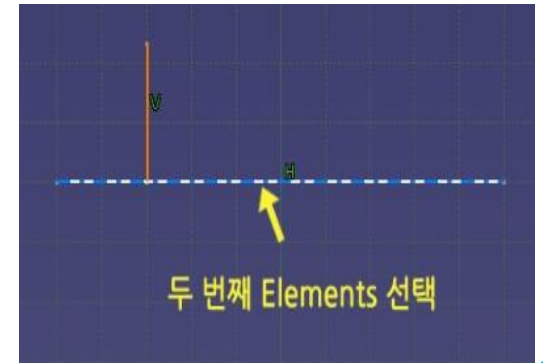

# 1 CADD(Computer Aided Design and Drafting)

## 2D Sketch 실습

### Trim

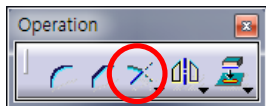

### 3- 2 Break



- 한 개의 Element를 절단하여 두 개의 Element로 분리하는 기능

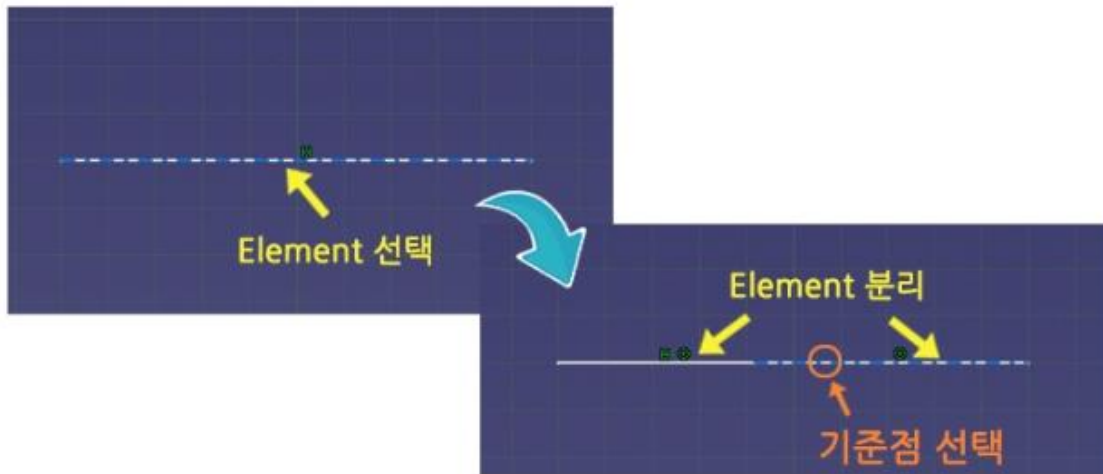

# 1 CADD(Computer Aided Design and Drafting)

## 2D Sketch 실습

### Trim

#### 3- 3 Quick Trim

- 교차점 기준으로 Trim 또는 Break 하는 기능

#### 1. Break and Rubber In

- 교차점 기준으로 선택한 Element 제거

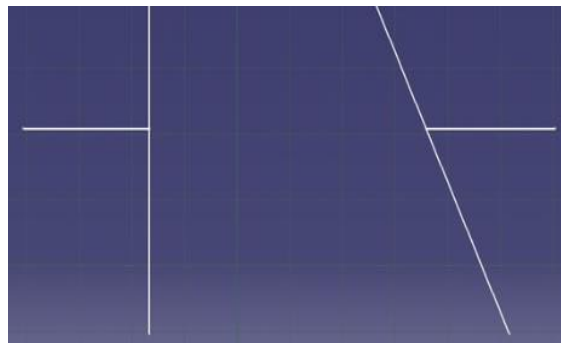
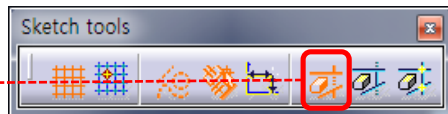
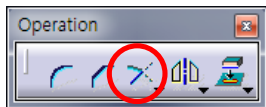

# 1 CADD (Computer Aided Design and Drafting)

## 2D Sketch 실습

### Trim

#### 3- 3 Quick Trim

- 교차점 기준으로 Trim 또는 Break 하는 기능

#### 2. Break and Rubber Out

- 교차점 기준으로 선택한 Element 를 제외하고 제거

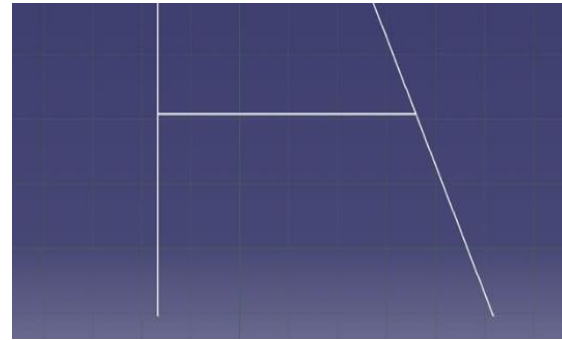
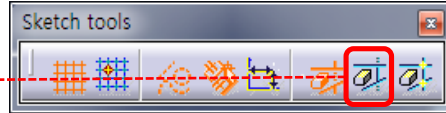
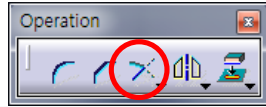

# 1 CADD(Computer Aided Design and Drafting)

## 2D Sketch 실습

### Trim

#### 3- 3 Quick Trim

- 교차점 기준으로 Trim 또는 Break 하는 기능

#### 3. Break and Keep

- 교차점 기준으로 선택한 Element 를 Break

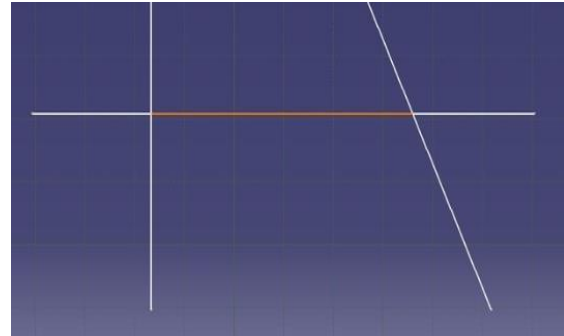
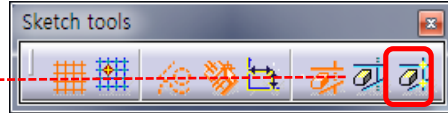
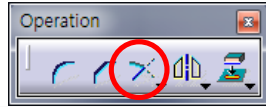

# 1 CADD(Computer Aided Design and Drafting)

## 2D Sketch 실습

Trim

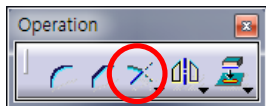

3- 4 Close Arc



- 원호(Arc) 또는 타원(Ellipse)의 Profile이 열려있을 때 닫아주는 기능

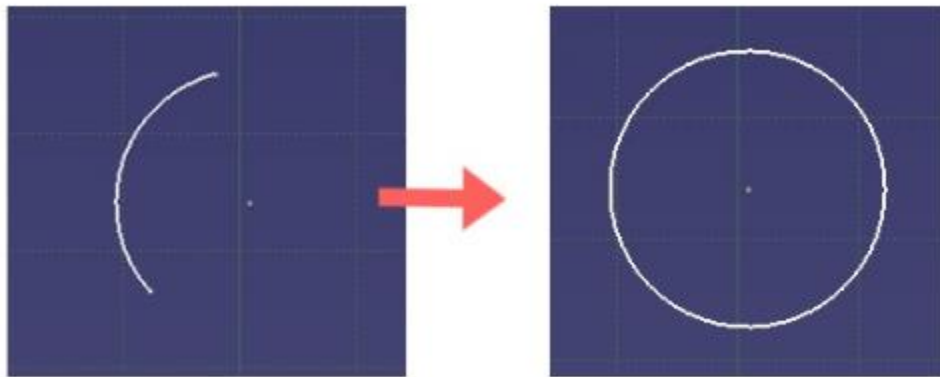

# 1 CADD(Computer Aided Design and Drafting)

## 2D Sketch 실습

### Trim

#### 3- 5 Complement

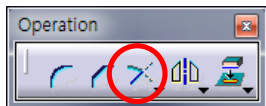

- 열려(Open)되어 있는 원호(Arc) 또는 타원(Ellipse)의 Profile을 반대 방향으로 전환시켜주는 기능

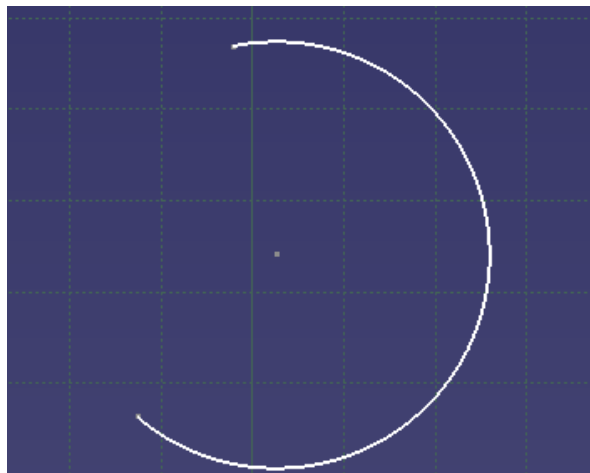
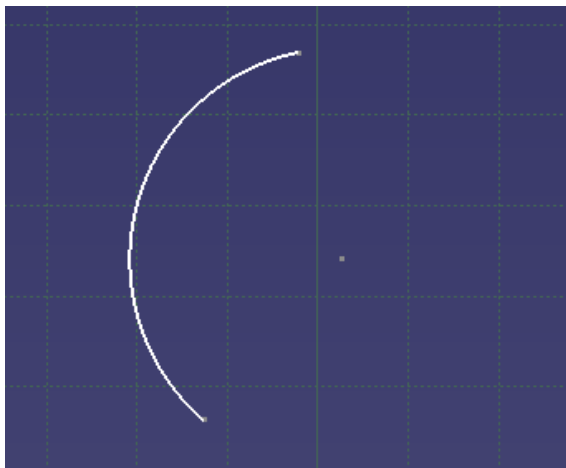

# 1 CADD(Computer Aided Design and Drafting)

## 2D Sketch 실습

### Mirror

#### 4-1 Mirror

- Axis 기준으로 선택한 Element를 대칭으로 복사하는 기능

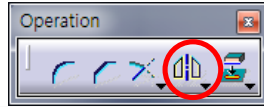
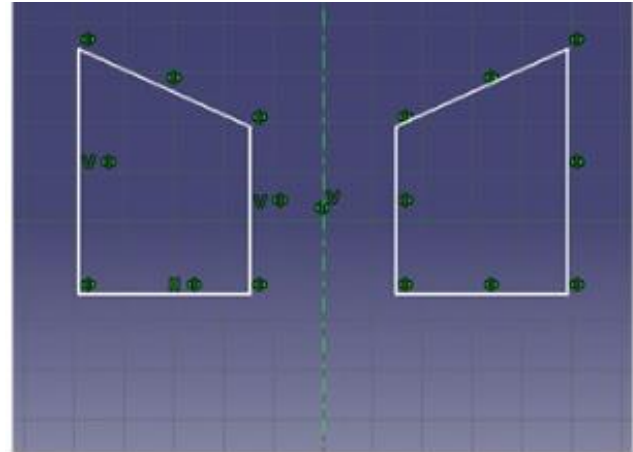
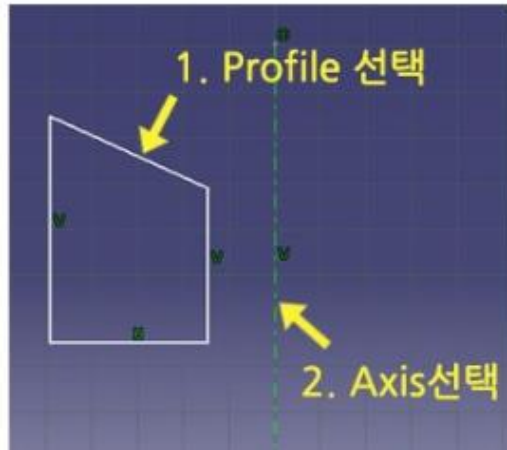



# 1 CADD(Computer Aided Design and Drafting)

## 2D Sketch 실습

### Mirror

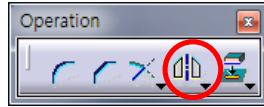

### 4 -2 Symmetry



- Axis 기준으로 선택한 Element를 대칭으로 이동하는 기능

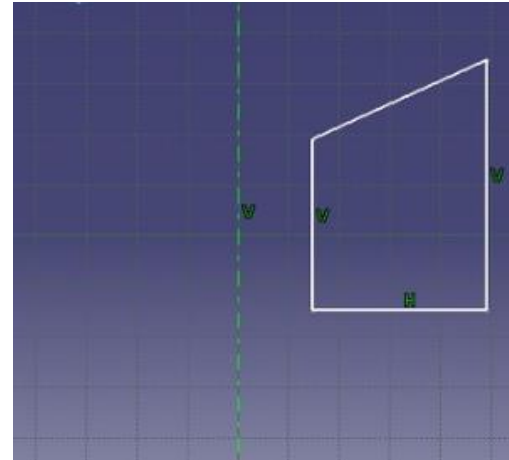
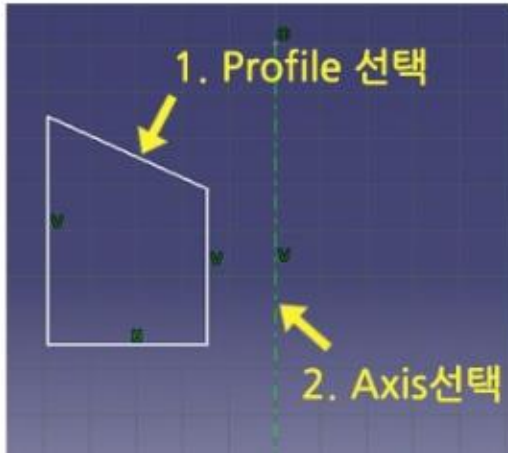

# 1 CADD(Computer Aided Design and Drafting)

## 2D Sketch 실습

### Mirror

#### 4 -3 Translate

- 선택한 Element를 이동하거나 복사하는 기능

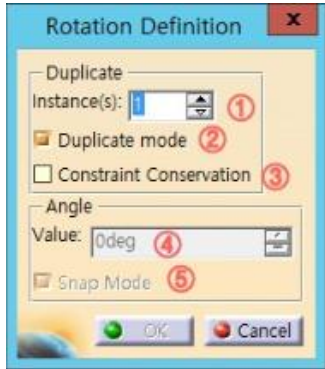
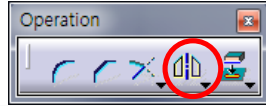

- ① Instance(s) : 복사할 개수 (Duplicate mode 활성화시 수행 가능)
- ② Duplicate mode : 활성화시 복사 기능 / 비 활성화시 회전 기능
- ③ Constraint Conservation : 복사본 구속조건 포함
- ④ Value : 회전 / 복사 시 거리 값
- ⑤ Snap Mode : 마우스 커서 조작 시 5deg 단위로 조정

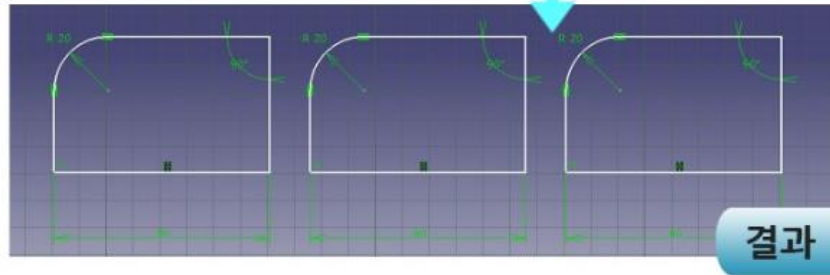
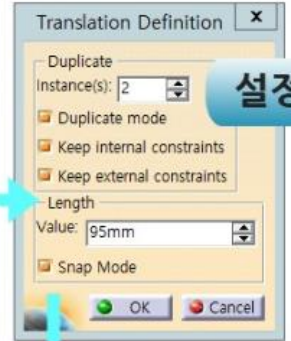
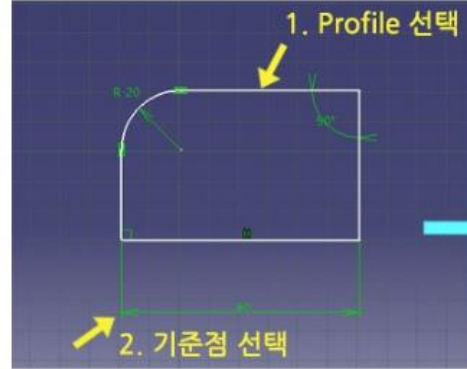

# 1 CADD(Computer Aided Design and Drafting)

## 2D Sketch 실습

### Mirror

#### 4 -4 Rotate

- 선택한 Element를 임의의 축 기준으로 회전 이동 또는 회전 복사하는 기능

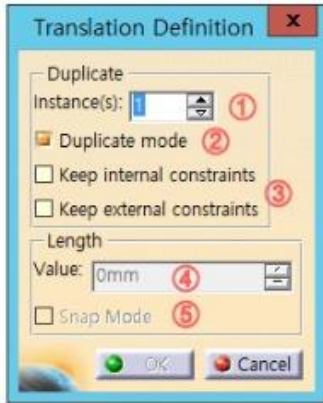
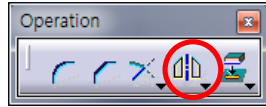

- ① Instance(s) : 복사할 개수 (Duplicate mode 활성화 시 수행 가능)
- ② Duplicate mode : 활성화 시 복사 가능 / 비 활성화 시 이동 가능
- ③ Keep internal / external constraints : 복사 시 구속조건 포함
- ④ Value : 이동 / 복사 시 거리 값
- ⑤ Snap Mode : 마우스 커서 조작 시 5mm 단위로 조정

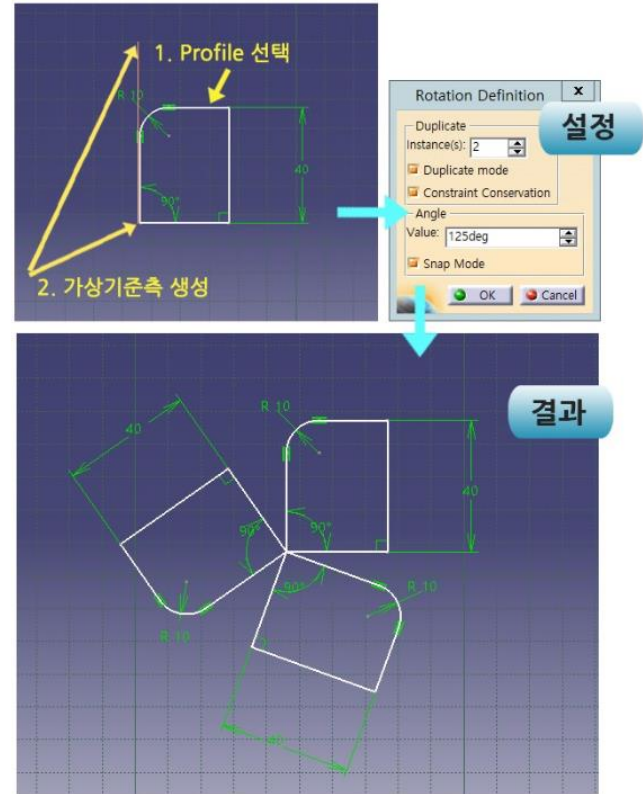

# 1 CADD(Computer Aided Design and Drafting)

## 2D Sketch 실습

### Mirror

#### 4 -5 Scale

- 선택한 Element를 임의의 Point 기준으로 대상을 확대 또는 축소하는 기능

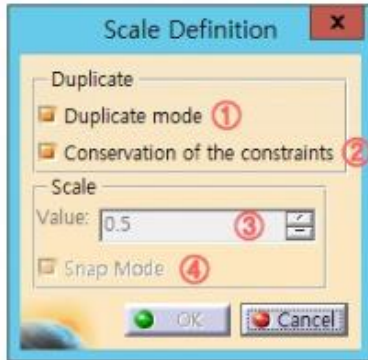
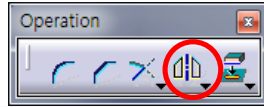

- ① Duplicate mode : 활성화시 복사본 축소,확대 가능  
비활성화시 원본 축소,확대 가능
- ② Conservation of the constraints : 복사본 구속조건 포함
- ③ Value : 축소, 확대 Ratio값
- ④ Snap Mode : 마우스 커서 조작시 0.1 단위로 조정

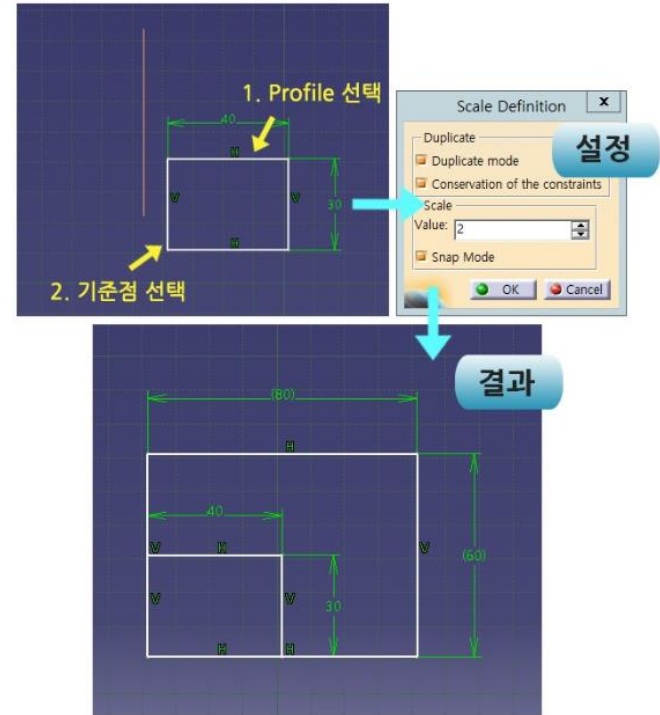

# 1 CADD(Computer Aided Design and Drafting)

## 2D Sketch 실습

### Mirror

#### 4 -6 Offset

- 선택한 Element를 수직방향으로 복사하는 기능



- ① No Propagation : 선택한 Element만 Offset
- ② Tangent Propagation : 선택한 Element와 Tangency한 Element를 Offset
- ③ Point Propagation : 선택한 Element와 Point로 연결 된 Element를 Offset
- ④ Both Propagation : 선택한 Element를 양방향으로 Offset

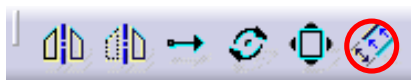
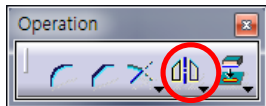

# 1 CADD (Computer Aided Design and Drafting)

## 2D Sketch 실습

Mirror

4 -6 Offset

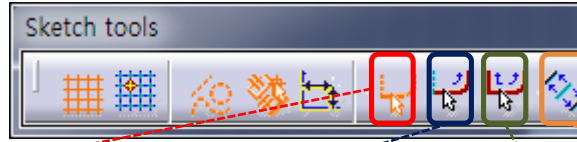
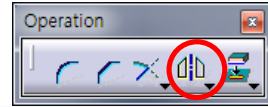

①

②

③

④

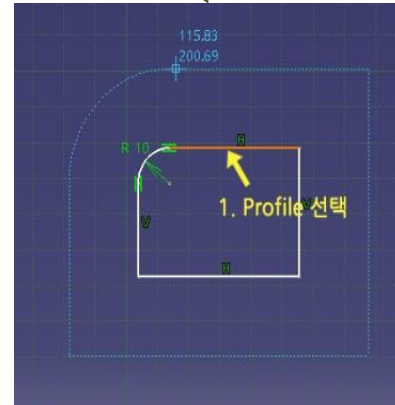

CADD (Computer Aided Design and Drafting)

## II 예제 도면을 통한 실습

# 3 CADD (Computer Aided Design and Drafting)

## 예제 도면을 통한 실습

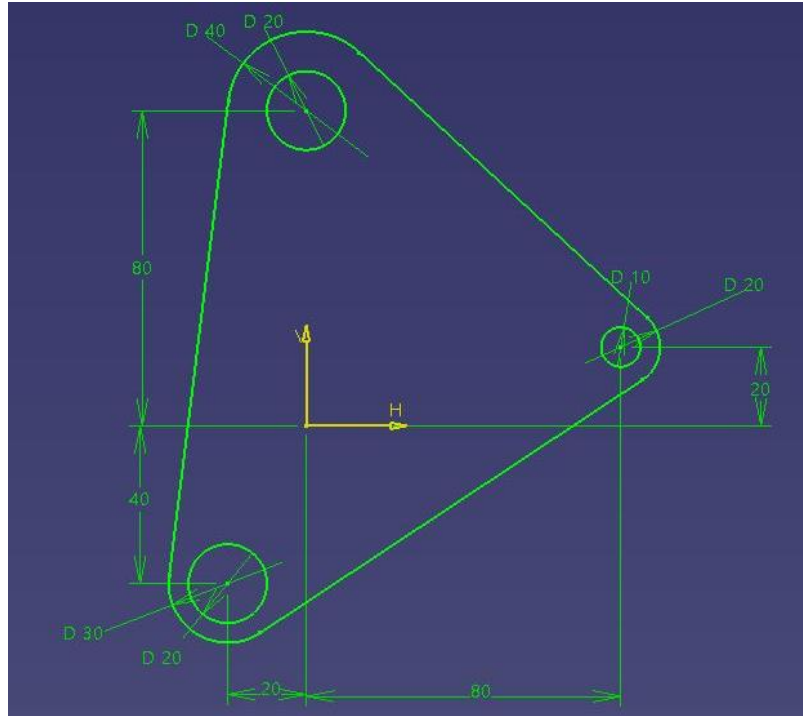



# 3 CADD (Computer Aided Design and Drafting)

## 예제 도면을 통한 실습

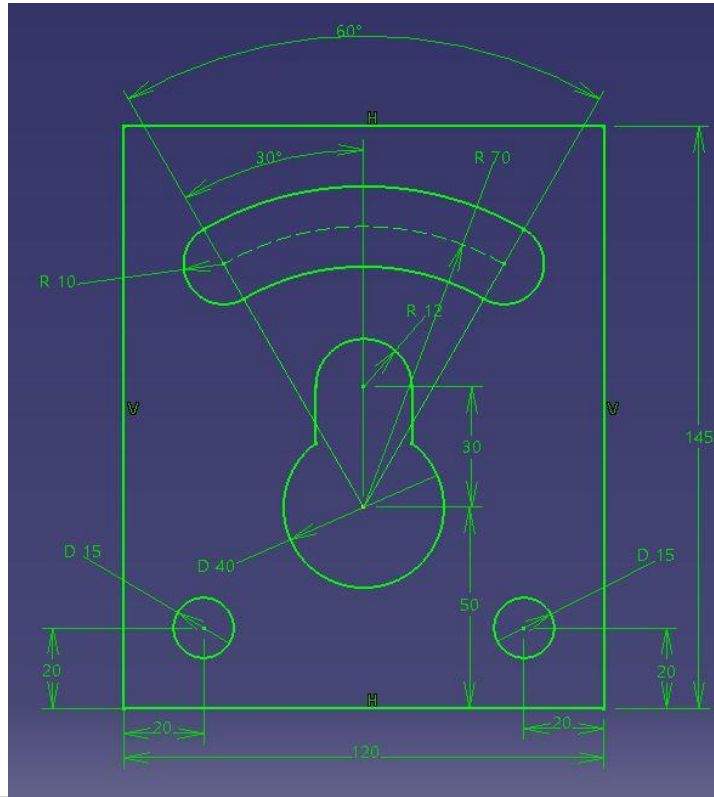

# 감사합니다

## 2021 학년도 기계공학과 CADD (MEE1002-24289)

CADD(Computer Aided Design and Drafting)

Constraint(구속조건 지정)

한양대학교

터보기계연구실

Prof. Keun Ryu, 실습조교 : 허준원

2021년 9월 27일 월요일



HANYANG UNIVERSITY



CADD(Computer Aided Design and Drafting)

# CONTENTS

 **Constraint**

CADD (Computer Aided Design and Drafting)

# I Constraint

# 1 CADD(Computer Aided Design and Drafting)

## Constraint(구속조건 지정)

### Constraint

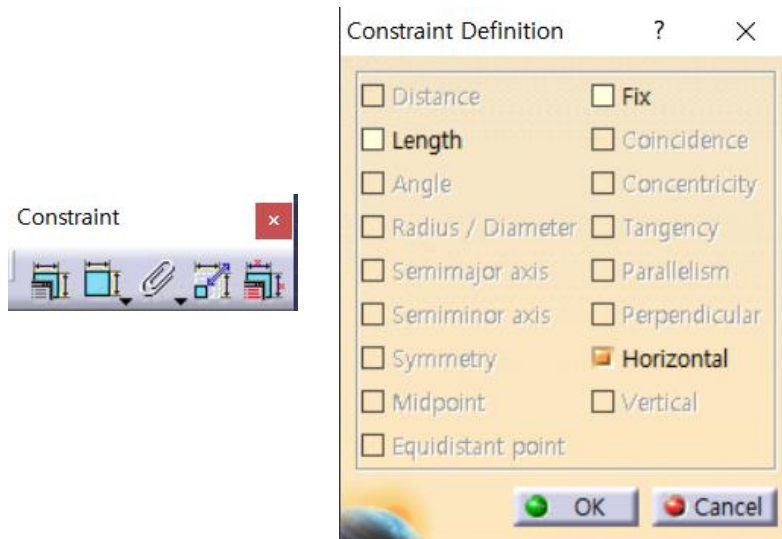

- Constraints란? Element의 길이, 반경, 거리, 각도 등과 형상에 필요한 구속조건을 지정하는 기능
- Constraint Definition : 조건들을 체크하는 방식으로 치수 및 형상의 구속조건을 정의

# 1 CADD(Computer Aided Design and Drafting)

## Constraint(구속조건 지정)

### Line

1. Line 명령어를 이용하여 선을 생성한다.
2. Line을 선택하고 “Constraints Defined in Dialog Box” 아이콘을 실행시킨다.
3. 옆의 그림처럼 Dialog Box에 Line에 구속 조건을 부여 할 수 있는 항목이 활성화된다.

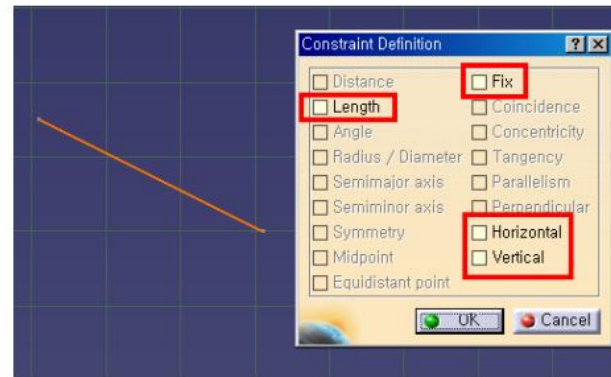

# 1 CADD(Computer Aided Design and Drafting)

## Constraint(구속조건 지정)

### Line

#### 4. Length : 길이에 대한 구속

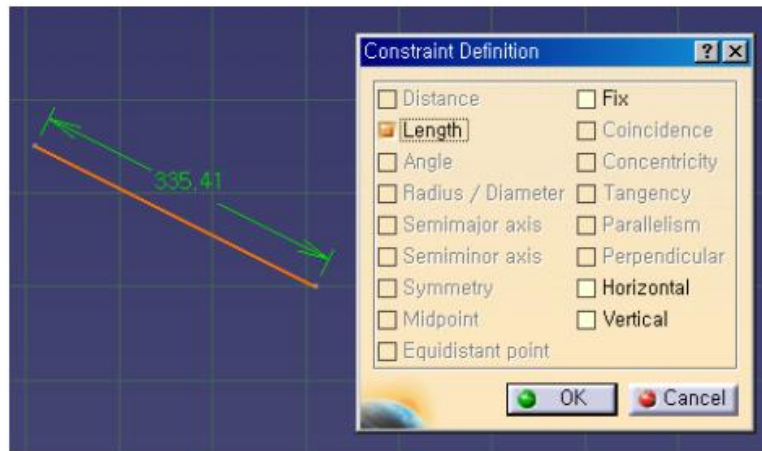



# 1 CADD(Computer Aided Design and Drafting)

## Constraint(구속조건 지정)

### Line

5. Fix : 하나 또는 그 이상의 Element의 위치를 고정시킨다.

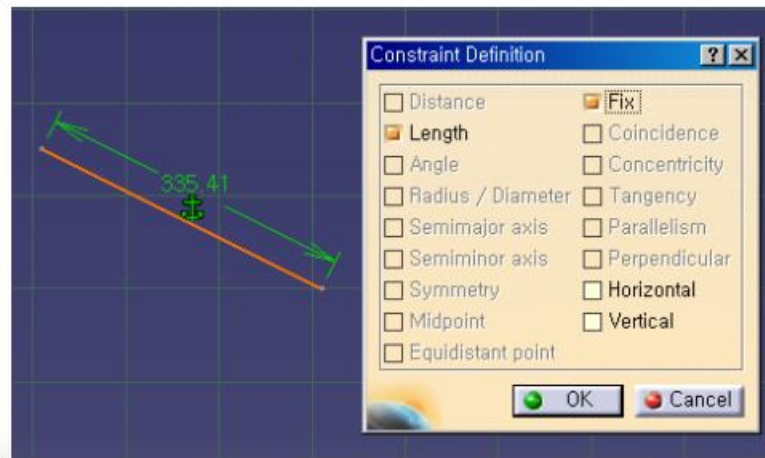

# 1 CADD(Computer Aided Design and Drafting)

## Constraint(구속조건 지정)

### Line

6. Horizontal : Line을 수평한 상태로 구속한다.

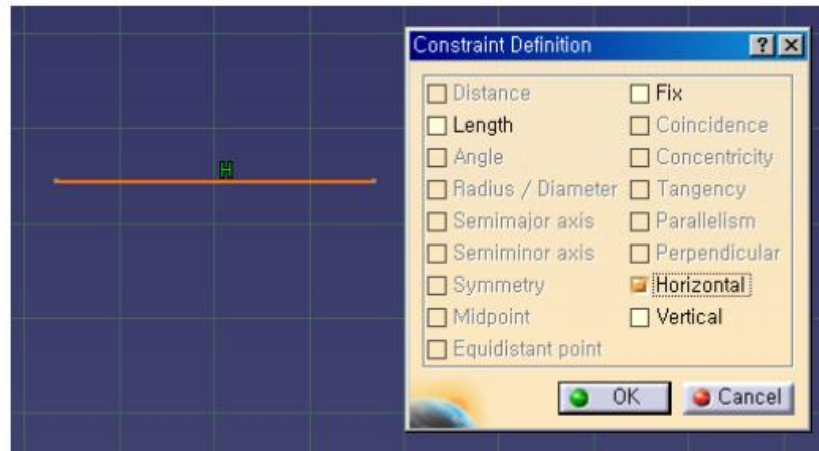

# 1 CADD(Computer Aided Design and Drafting)

## Constraint(구속조건 지정)

### Line

7.Virtual : Line을 수직한 상태로 구속한다.

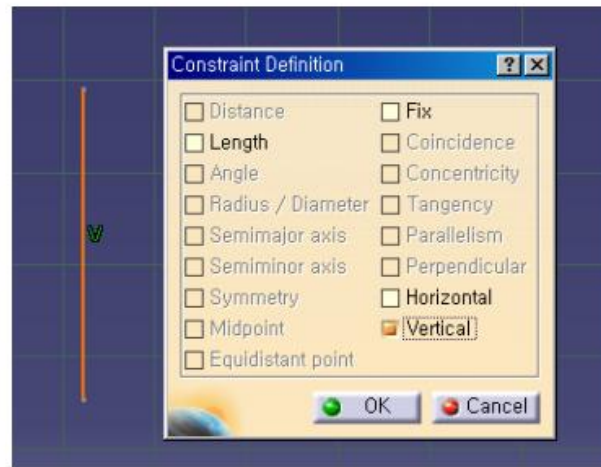

# 1 CADD(Computer Aided Design and Drafting)

## Constraint(구속조건 지정)

### Circle

1. Circle 명령어를 이용하여 원을 생성한다.
2. Line을 선택하고 “Constraints Defined in Dialog Box”  아이콘을 실행시킨다.
3. 옆의 그림처럼 Dialog Box에 원에 구속 조건을 부여 할 수 있는 항목이 활성화된다.

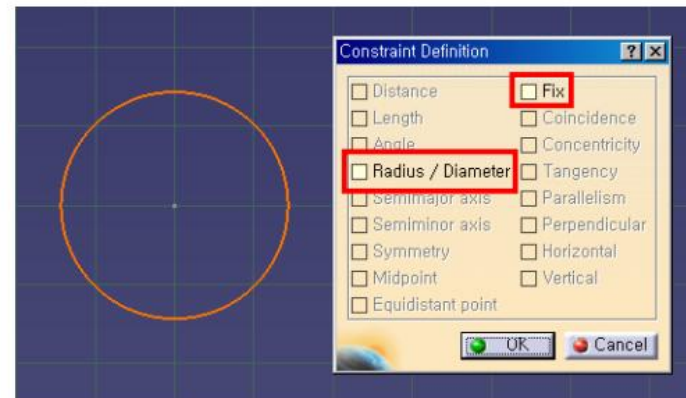

# 1 CADD(Computer Aided Design and Drafting)

## Constraint(구속조건 지정)

### Circle

#### 4. Radius/Diameter : 원의 지름을 구속함

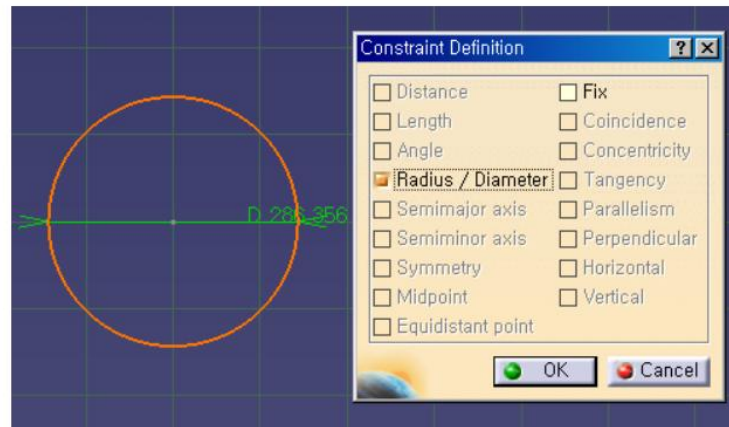

# 1 CADD(Computer Aided Design and Drafting)

## Constraint(구속조건 지정)

### Line and Circle

1. 원과 선을 각각 생성한다.
2. Line을 선택하고 “Constraints Defined in Dialog Box”  아이콘을 실행시킨다.
3. 옆의 그림처럼 Dialog Box에 원에 구속 조건을 부여 할 수 있는 항목이 활성화된다.

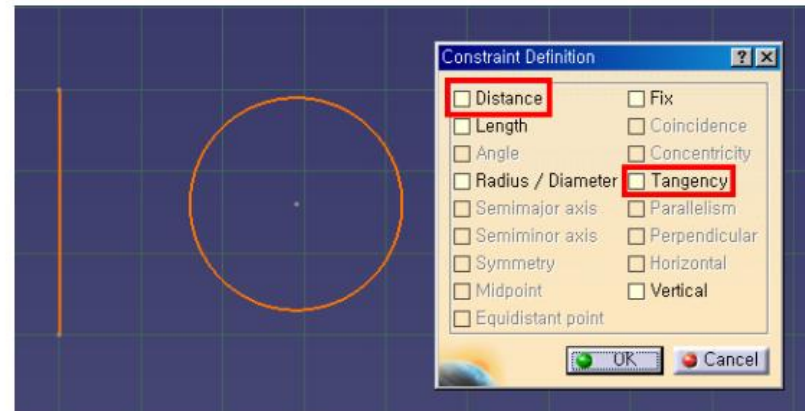

# 1 CADD(Computer Aided Design and Drafting)

## Constraint(구속조건 지정)

### Line and Circle

4. Distance : 선과 원을 모두 선택한 다음 두 요소 사이의 거리에 대한 구속을 부여.

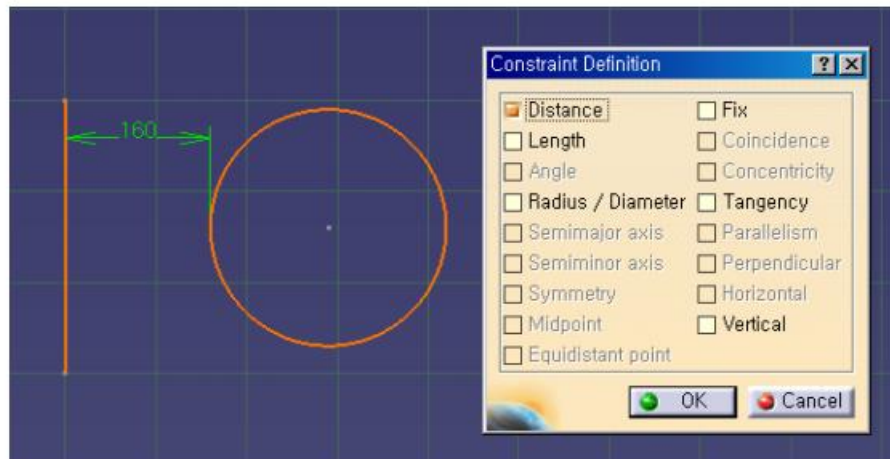

# 1 CADD(Computer Aided Design and Drafting)

## Constraint(구속조건 지정)

### Line and Circle

5. Tangency : 선과 원을 모두 선택한 다음 선이 원의 접선이 되도록 구속을 부여

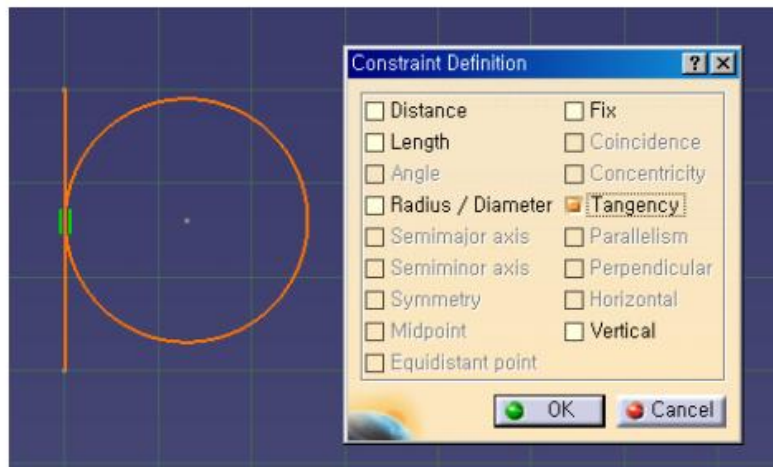



# 1 CADD(Computer Aided Design and Drafting)

## Constraint(구속조건 지정)

### Lines

1. 선을 2개 생성한다.
2. Line을 선택하고 “Constraints Defined in Dialog Box”  아이콘을 실행시킨다.
3. 옆의 그림처럼 Dialog Box에 원에 구속 조건을 부여 할 수 있는 항목이 활성화된다.

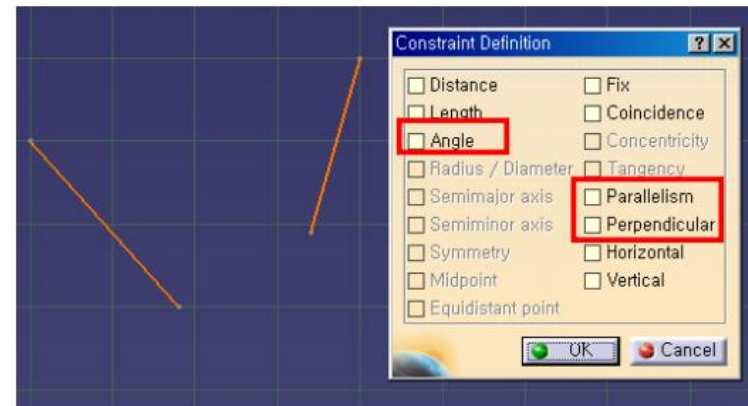

# 1 CADD(Computer Aided Design and Drafting)

## Constraint(구속조건 지정)

### Lines

#### 4. Angle: 두 요소 사이의 각도를 구속

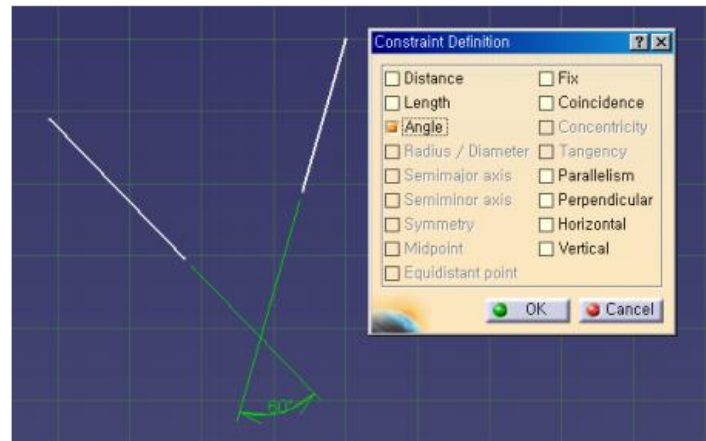

# 1 CADD(Computer Aided Design and Drafting)

## Constraint(구속조건 지정)

### Lines

#### 5. Parallelism: 두 선이 평행하게 구속

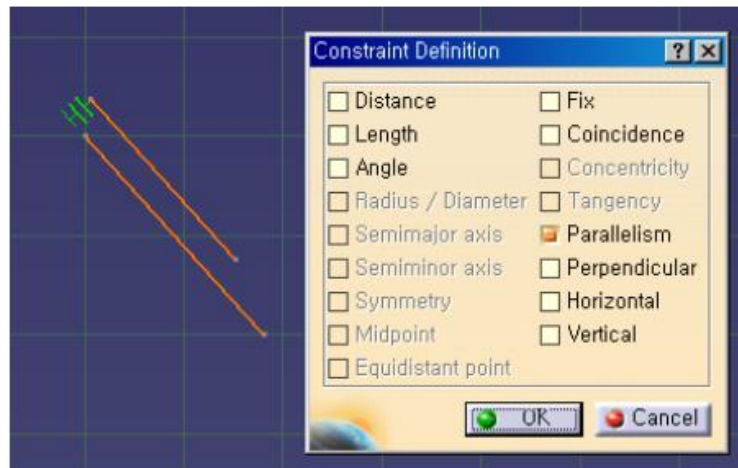

# 1 CADD(Computer Aided Design and Drafting)

## Constraint(구속조건 지정)

### Lines

6. Perpendicular: 두 선이 직각이 되도록 구속

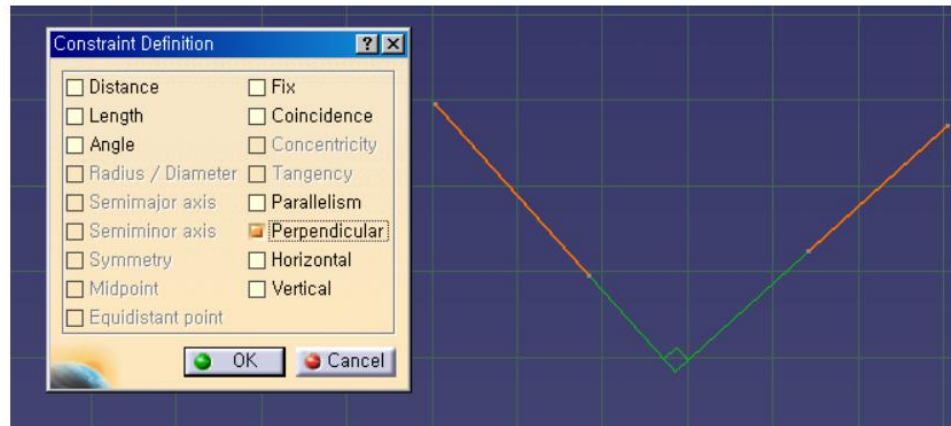

# 1 CADD(Computer Aided Design and Drafting)

## Constraint(구속조건 지정)

### Circles

1. 원을 2개 생성한다.
2. Line을 선택하고 “Constraints Defined in Dialog Box”  아이콘을 실행시킨다.
3. 옆의 그림처럼 Dialog Box에 원에 구속 조건을 부여 할 수 있는 항목이 활성화된다.

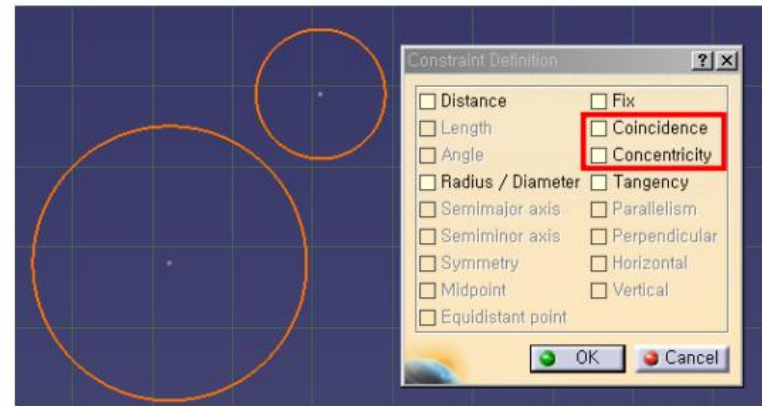

# 1 CADD(Computer Aided Design and Drafting)

## Constraint(구속조건 지정)

### Circles

#### 4. Coincidence: 두 원의 크기와 위치를 일치시키는 구속을 부여

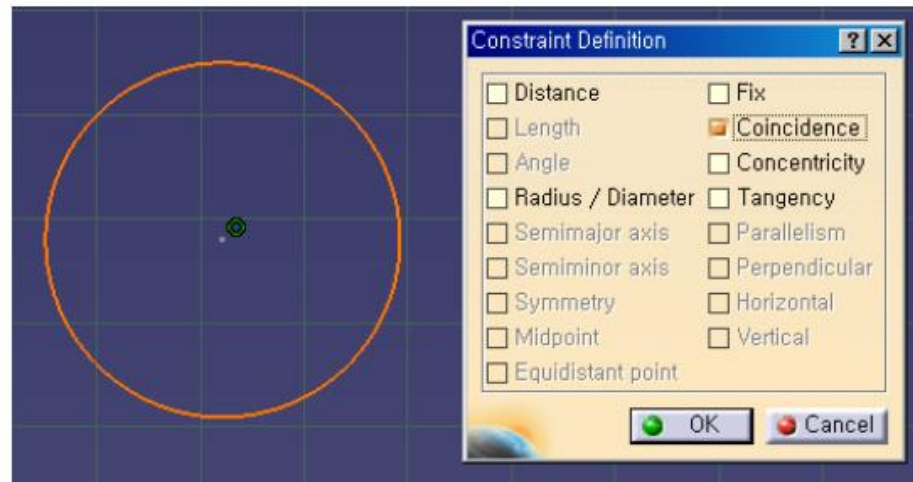

# 1 CADD(Computer Aided Design and Drafting)

## Constraint(구속조건 지정)

### Circles

#### 5. Concentricity: 두 원의 중심을 일치시키는 구속을 부여

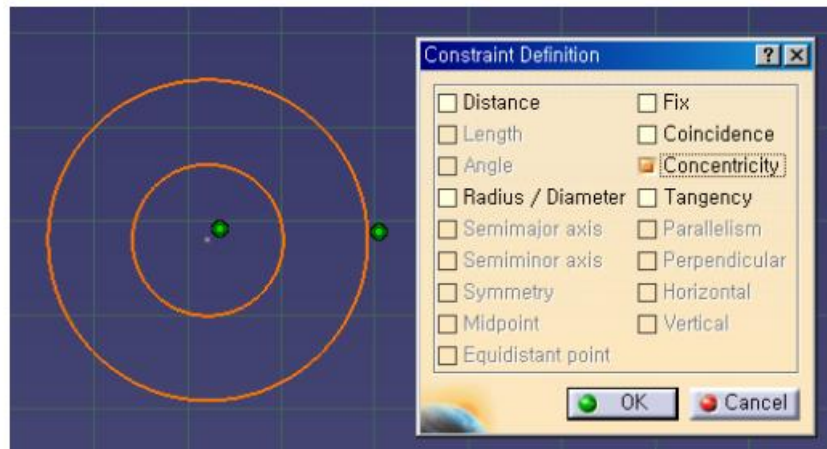

# 1 CADD(Computer Aided Design and Drafting)

## Constraint(구속조건 지정)

### Line and Rectangle

1. 사각형과 선을 각각 생성한다.
2. Line을 선택하고 “Constraints Defined in Dialog Box”  아이콘을 실행시킨다.
3. 옆의 그림처럼 Dialog Box에 원에 구속 조건을 부여 할 수 있는 항목이 활성화된다.

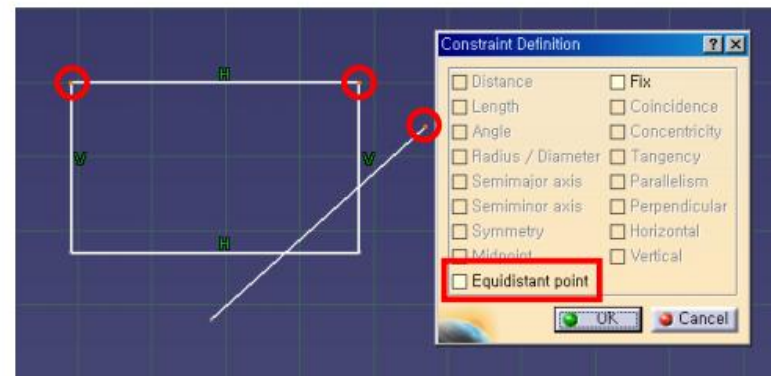



# 1 CADD(Computer Aided Design and Drafting)

## Constraint(구속조건 지정)

### Line and Rectangle

4. Equidistant Point : 선택한 점들의 간격이 일정하도록 구속을 부여

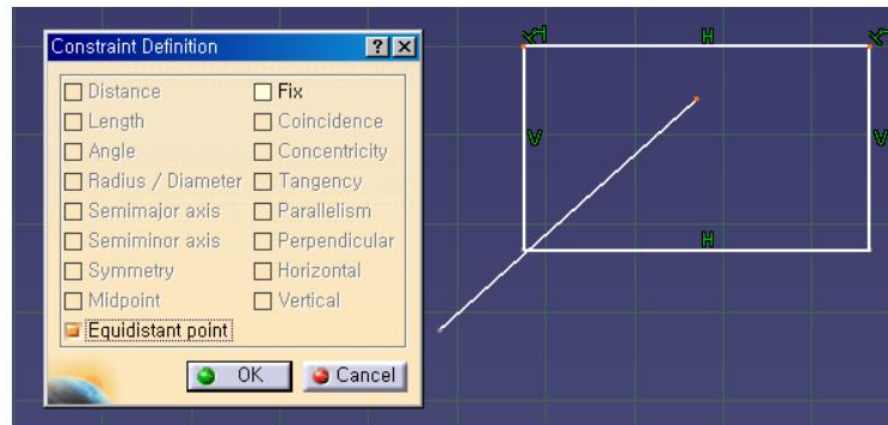

# 1 CADD(Computer Aided Design and Drafting)

## Constraint(구속조건 지정)

### Line and Rectangle

1. 사각형과 선을 각각 생성한다.
2. Line을 선택하고 “Constraints Defined in Dialog Box”  아이콘을 실행시킨다.
3. 옆의 그림처럼 Dialog Box에 원에 구속 조건을 부여 할 수 있는 항목이 활성화된다.

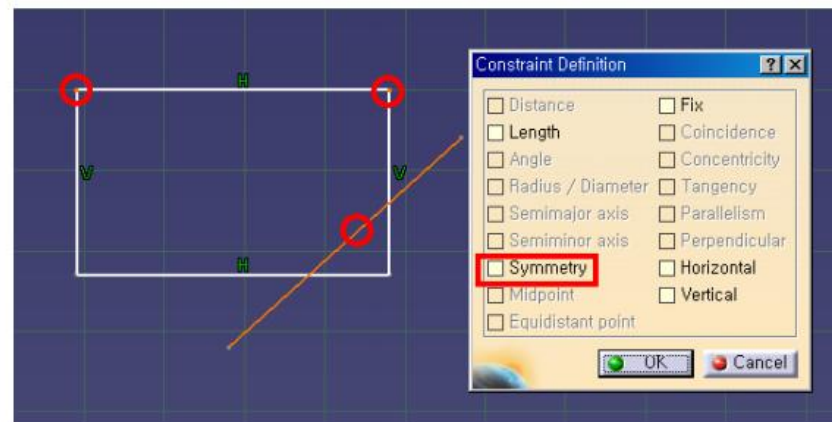

# 1 CADD(Computer Aided Design and Drafting)

## Constraint(구속조건 지정)

### Line and Rectangle

4. Symmetry : 선택된 두 요소가 중심이 되는 하나의 선을 기준으로 대칭이 되도록 구속

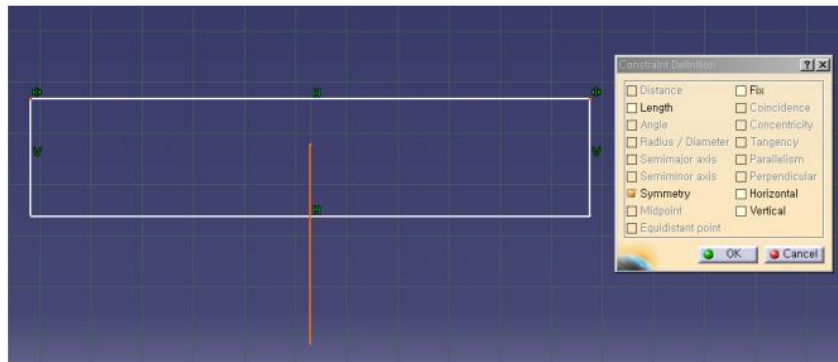

# 감사합니다

